



100% ELECTRIC

MOTOR

 150 kW

BATTERIES

 115 kWh

RANGE

 270 km
(SORT 2)

CHARGING

 120 kW



**ALTAS NOVUS
Cityline/Cityline LW**

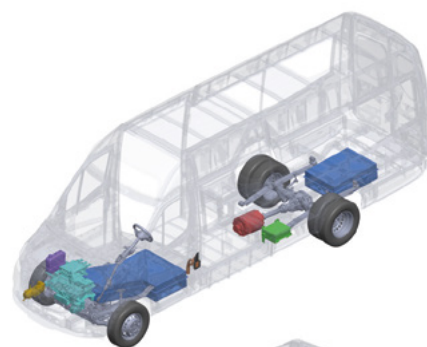

**ALTAS NOVUS
Ecoline/Multiline**

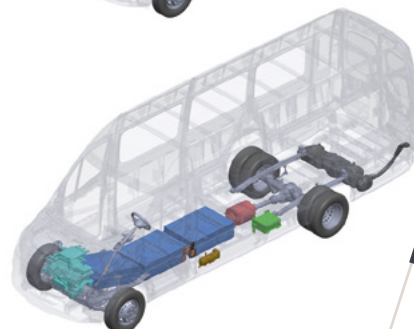

ALTAS NOVUS CITYLINE/CITYLINE LW

M3 Class A minibus



Passenger capacity

In total	22
Sitting places	13/14*
Wheelchair	1**

Dimensions and weight

Lenght (mm)	7367/7667***
Width (mm)	2020
Height (mm)	2880
Wheelbase (mm)	4325/5025***
Permitted GVW (kg)	5900
Entrance door width (mm)	1200
Entrance step height from the ground (mm)	250
Internal height (mm)	1900/2250

Driveline

Chassis	Mercedes-Benz Sprinter
Electric driveline producer	Elinta Motors
Drivetrain	Direct shaft to rear axle
Engine type	Asynchronous
Max engine power (kW)	150
Max torque (Nm)	1250
Max speed (km/h)	80
Energy consumption (kWh/100 km)	39
Range (km) (SORT 2)	270

Batteries

Battery technology	NMC
Battery capacity (kWh)	115 (3x38,3)
Nominal voltage (V)	400
Slow charging AC power (kW)	19,7 (Type 2)
Fast charging DC power (kW)	120 (CCS)

Heating and conditioning

Passengers' compartment air conditioning (kW)	5/13 *
Interior electric liquid heater (kW)	5+2****
Autonomous HVO diesel Webasto heater (kW) *****	9

* Depends on the layout. ** One passenger with a wheelchair reduces the total capacity by 3 pass. *** Cityline/Cityline LW. **** 2 kW original chassis heater in the driver compartment. ***** Optional

ALTAS NOVUS ECOLINE/MULTILINE

M3 Class B minibus

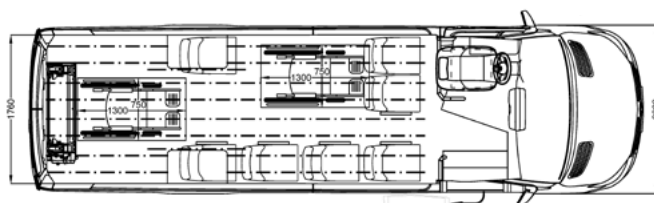
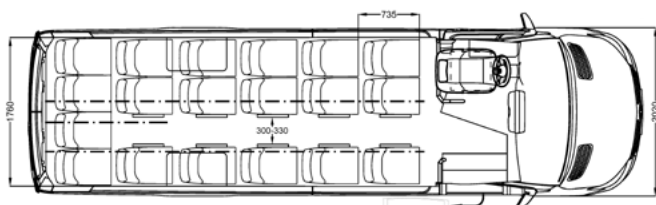

Passenger capacity

In total	16/19*
Sitting places	16/19*
Wheelchair	2*

Dimensions and weight

Lenght (mm)	7367
Width (mm)	2020
Height (mm)	2880
Wheelbase (mm)	4325
Permitted GVW (kg)	5900
Entrance door width (mm)	1200
Entrance step height from the ground (mm)	250
Internal height (mm)	1900

Driveline

Chassis	Mercedes-Benz Sprinter
Electric driveline producer	Elinta Motors
Drivetrain	Direct shaft to rear axle
Engine type	Asynchronous
Max engine power (kW)	150
Max torque (Nm)	1250
Max speed (km/h)	100
Energy consumption (kWh/100 km)	39
Range (km) (SORT 2)	270

Batteries

Battery technology	NMC
Battery capacity (kWh)	115 (3x38,3)
Nominal voltage (V)	400
Slow charging AC power (kW)	19,7 (Type 2)
Fast charging DC power (kW)	120 (CCS)

Heating and conditioning

Passengers' compartment air conditioning (kW)	5/13*
Interior electric liquid heater (kW)	5+2**
Autonomous HVO diesel Webasto heater (kW) ***	9

* Depends on the layout. ** 2 kW original chassis heater in the driver compartment *** Optional

ALTAS AUTO

Centrine str. 30 Pikutiskes,
LT-14300 LITHUANIA

info@altasauto.com
www.altasauto.com

Office +370 52 404 000
Support 24/7 +370 52 177 177

